

FCI PART NUMBER	DESCRIPTION (SEE LAST SHEET)
10129954-TXXXXYYLF	EXaMAX I/O 2.0mm 4-PAIR 8-COLUMN RIBBONIZED CABLE ASSEMBLY (AS SHOWN - SEE SHEETS 5 & 6 FOR MORE DETAILED INFORMATION)

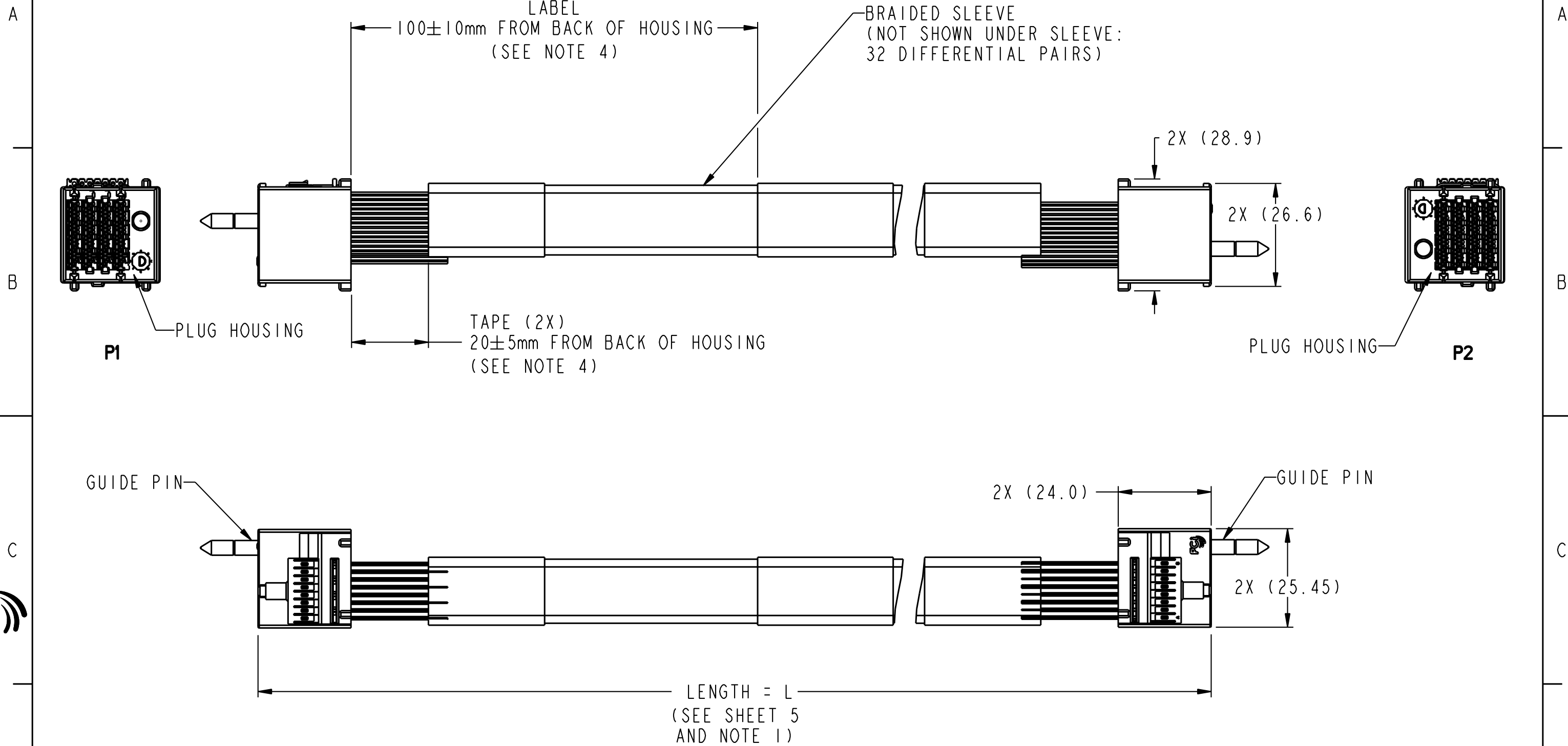

PRELIMINARY

10129954-TXXXX2GLF AS SHOWN

spec ref	-	dr	J. WINEY	2014-10-02	projection	mm	size	A3	scale	1:1
tolerance std	ASME Y14.5	eng	K. WEBER	2014-10-02			ecn no	rel level	In Work	rev
TOLERANCES UNLESS OTHERWISE SPECIFIED		chr	K. WEBER	2014-10-02						
surface	✓	appr			product family	-				
	linear		0.X	±		EXAMAX I/O, 4X8-2.0mm PITCH PASSIVE LATCH BACK PLANE CABLE ASSY	dwg no 10129954	sheet 1 of 6	rev 2	cat. no. -
			0.XX	±						
	angular		0°	±°						

Copyright FCI.

FCI PART NUMBER	DESCRIPTION (SEE LAST SHEET)
10129954-TXXXXYYLF	ExaMAX I/O 2.0mm 4-PAIR 8-COLUMN RIBBONIZED CABLE ASSEMBLY (AS SHOWN - SEE SHEETS 5 & 6 FOR MORE DETAILED INFORMATION)

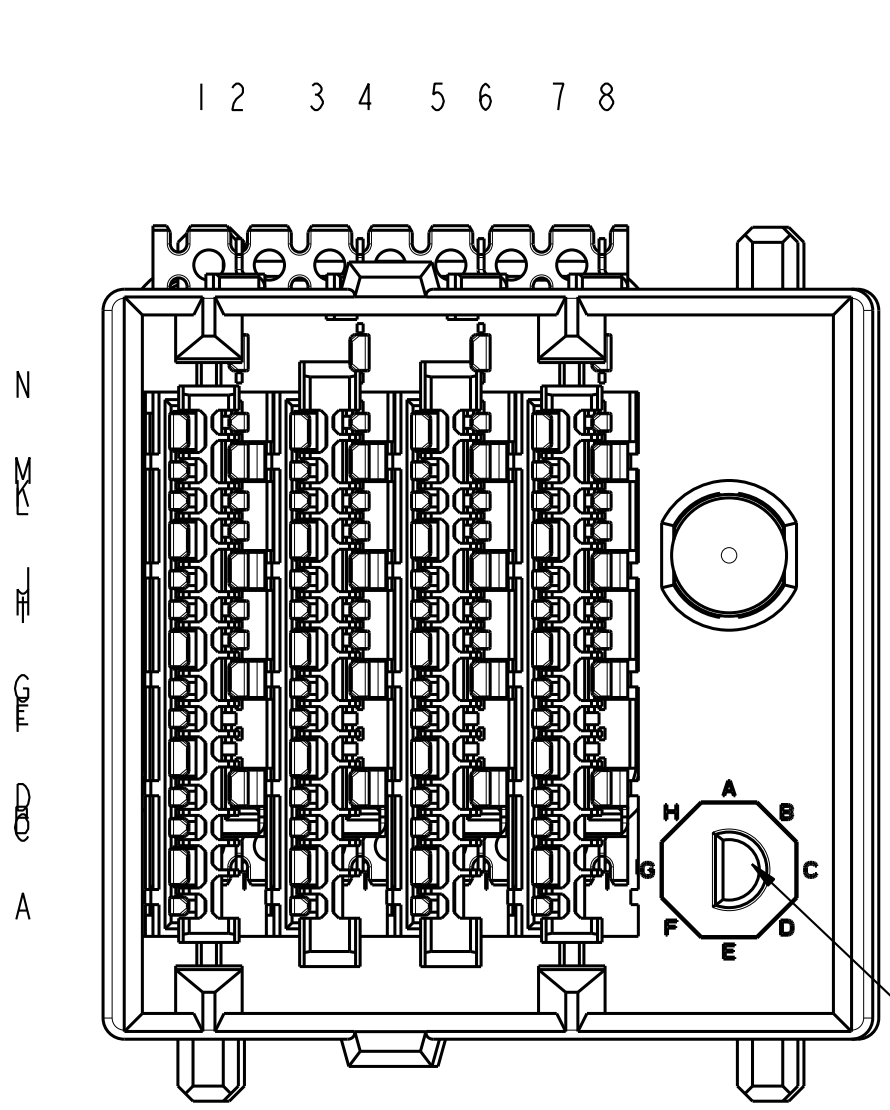

A B A B A B A B

**P1
SCALE 4:1**

KEY PIN
(OPTIONAL)
SEE NOTE 13

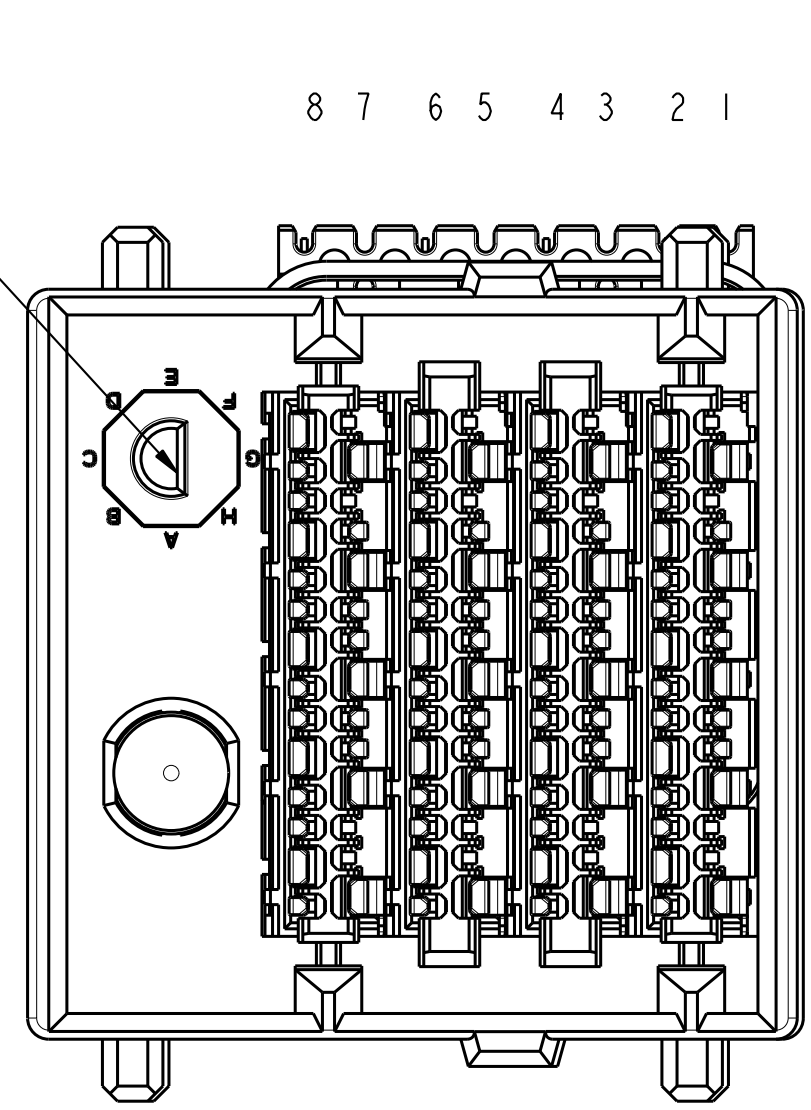

B A B A B A B A

**P2
SCALE 4:1**

KEY PIN
(OPTIONAL)
SEE NOTE 13



Copyright FCI.

PRELIMINARY

10129954-TXXXX2GLF AS SHOWN

spec ref	-	dr	J. WINEY	2014-10-02	projection	mm	size	A3	scale	1:1																								
tolerance std	ASME Y14.5	eng	K. WEBER	2014-10-02			ecn no		rel level																									
TOLERANCES UNLESS OTHERWISE SPECIFIED		chr	K. WEBER	2014-10-02			-		In Work																									
surface	<table border="1"> <tr> <td>linear</td> <td>0.X</td> <td>±</td> </tr> <tr> <td></td> <td>0.XX</td> <td>±</td> </tr> <tr> <td></td> <td>0.XXX</td> <td>±</td> </tr> <tr> <td>angular</td> <td>0°</td> <td>±°</td> </tr> </table>	linear	0.X	±		0.XX	±		0.XXX	±	angular	0°	±°			<table border="1"> <tr> <td>title</td> <td>EXAMAX IO, 4X8-2.0mm PITCH</td> <td>dwg no</td> <td>10129954</td> <td>rev</td> <td>2</td> </tr> <tr> <td></td> <td>PASSIVE LATCH BACK PLANE CABLE ASSY</td> <td></td> <td></td> <td></td> <td></td> </tr> </table>	title	EXAMAX IO, 4X8-2.0mm PITCH	dwg no	10129954	rev	2		PASSIVE LATCH BACK PLANE CABLE ASSY					<table border="1"> <tr> <td>cat. no.</td> <td>-</td> <td>Product - Customer Drw</td> <td>sheet 2 of 6</td> </tr> </table>		cat. no.	-	Product - Customer Drw	sheet 2 of 6
linear	0.X	±																																
	0.XX	±																																
	0.XXX	±																																
angular	0°	±°																																
title	EXAMAX IO, 4X8-2.0mm PITCH	dwg no	10129954	rev	2																													
	PASSIVE LATCH BACK PLANE CABLE ASSY																																	
cat. no.	-	Product - Customer Drw	sheet 2 of 6																															

FCI PART NUMBER	DESCRIPTION (SEE LAST SHEET)
10129954-TXXXXYYLF	EXaMAX I/O 2.0mm 4-PAIR 8-COLUMN RIBBONIZED CABLE ASSEMBLY

PIN-OUT CONFIGURATION (P1 & P2)

SEE NOTE 18

	1	2	3	4	5	6	7	8	
	GND	LS2	GND	LS4	GND	LS6	GND	LS8	N
	TX1+	GND	TX5+	GND	TX9+	GND	TX13+	GND	M
	TX1-	TX3+	TX5-	TX7+	TX9-	TX11+	TX13-	TX15+	L
	GND	TX3-	GND	TX7-	GND	TX11-	GND	TX15-	K
	TX2+	GND	TX6+	GND	TX10+	GND	TX14+	GND	J
	TX2-	TX4+	TX6-	TX8+	TX10-	TX12+	TX14-	TX16+	I
	GND	TX4-	GND	TX8-	GND	TX12-	GND	TX16-	H
	RX2-	GND	RX6-	GND	RX10-	GND	RX14-	GND	G
	RX2+	RX4-	RX6+	RX8-	RX10+	RX12-	RX14+	RX16-	F
	GND	RX4+	GND	RX8+	GND	RX12+	GND	RX16+	E
	RX1-	GND	RX5-	GND	RX9-	GND	RX13-	GND	D
	RX1+	RX3-	RX5+	RX7-	RX9+	RX11-	RX13+	RX15-	C
	GND	RX3+	GND	RX7+	GND	RX11+	GND	RX15+	B
	LS1	GND	LS3	GND	LS5	GND	LS7	GND	A
	A	B	A	B	A	B	A	B	

PRELIMINARY

spec ref -		dr J. WINEY	2014-10-02	projection	mm ↔	size A3	scale 1:1	
tolerance std	TOLERANCES UNLESS OTHERWISE SPECIFIED	eng K. WEBER	2014-10-02			ecn no	rel level	In Work
ASME Y14.5		chr K. WEBER	2014-10-02		product family -			
surface <input checked="" type="checkbox"/>		linear	0.X ±		title	EXAMAX IO, 4X8-2.0mm PITCH	dwg no	10129954
		0.XX ±						
		0.XXX ±						
	angular	0° ±°	www.fci.com	cat. no.	-	Product - Customer Drw	sheet 3 of 6	



Copyright FCI.

FCI PART NUMBER	DESCRIPTION
10129954-TXXXXYYLF	EXdMAX 10 2.0mm 4-PAIR 8-COLUMN RIBBONIZED CABLE ASSEMBLY

IMLA WIRING LIST		
	PI END	P2 END
IMLA COLUMN		IMLA COLUMN
1		
2		
3		
4		
5		
6		
7		
8		

DETAILED WIRING LIST for COLUMN 1 (A IMLA) (SEE NOTE 16)				
PI END		P2 END		
POSITION	SYMBOL		POSITION	SYMBOL
NI	GND	-----	BI	GND
MI	TX1+		CI	RX1+
LI	TX1-		DI	RX1-
KI	GND	-----	EI	GND
JI	TX2+		FI	RX2+
II	TX2-		GI	RX2-
HI	GND	-----	HI	GND
GI	RX2-		II	TX2-
FI	RX2+		JI	TX2+
EI	GND	-----	KI	GND
DI	RX1-		LI	TX1-
CI	RX1+		MI	TX1+
BI	GND	-----	NI	GND
AI	LS1	-----	AI	LS1

DETAILED WIRING LIST for COLUMN 2 (B IMLA) (SEE NOTE 16)				
PI END		P2 END		
POSITION	SYMBOL		POSITION	SYMBOL
N2	LS2	-----	N2	LS2
M2	GND	-----	A2	GND
L2	TX3+		B2	RX3+
K2	TX3-		C2	RX3-
J2	GND	-----	D2	GND
I2	TX4+		E2	RX4+
H2	TX4-		F2	RX4-
G2	GND	-----	G2	GND
F2	RX4-		H2	TX4-
E2	RX4+		I2	TX4+
D2	GND	-----	J2	GND
C2	RX3-		K2	TX3-
B2	RX3+		L2	TX3+
A2	GND	-----	M2	GND

spec ref	-	dr	J. WINEY	2014-10-02	projection		size	A3	scale	1:1	
tolerance std	ASME Y14.5	eng	K. WEBER	2014-10-02	mm		ecn no				
	TOLERANCES UNLESS OTHERWISE SPECIFIED	chr	K. WEBER	2014-10-02	product family	-	rel level	In Work			
surface		appr									
	linear					title	EXAMAX 10, 4X8-2.0mm PITCH	dwg no	10129954	rev	2
	angular				www.fci.com	cat. no.	-	Product - Customer Drw	sheet 4 of 6		



Copyright FCI.

10129954-TXXXXYYLF

CABLE IDENTIFICATION INFORMATION		
"T"	WIRE SIZE	DESCRIPTION
A	30 AWG	30AWG, HIGH SPEED RIBBONIZED, CABLE

30AWG PART NUMBERS		
LENGTH (DIM "L") = METERS		
CABLE ASSEMBLY PART NUMBER	=	METER(S)
10129954-A0050YYLF	=	0.50
10129954-A0100YYLF	=	1.00
10129954-A0150YYLF	=	1.50
10129954-A0200YYLF	=	2.00
10129954-A0250YYLF	=	2.50
10129954-A0300YYLF	=	3.00
10129954-A0350YYLF	=	3.50
10129954-A0400YYLF	=	4.00
10129954-A0450YYLF	=	4.50
10129954-A0500YYLF	=	5.00
10129954-A0550YYLF	=	5.50
10129954-A0600YYLF	=	6.00

MODULE DESCRIPTION	DESIGNATION REPRESENTED IN DASH NUMBER								
W/O END GUIDE MODULE	01								
RIGHT GUIDANCE MODULE	1A	1B	1C	1D	1E	1F	1G	1H	1J (NO KEY)
LEFT GUIDANCE MODULE	2A	2B	2C	2D	2E	2F	2G	2H	2J (NO KEY)

PRELIMINARY

spec ref	-	dr	J. WINEY	2014-10-02	projection		mm	size	A3	scale	3:10
tolerance std	ASME Y14.5	eng	K. WEBER	2014-10-02	chr	K. WEBER	2014-10-02	ecn no		rel level	In Work
surface	✓	appr			product family	-		rev	2		
	linear	0.X	±								
		0.XX	±								
		0.XXX	±								
	angular	0°	±°								
				title		EXAMAX 10, 4X8-2.0mm PITCH		dwg no		10129954	
		www.fci.com		cat. no.		-		Product - Customer Drw		sheet 5 of 6	



Copyright FCI.

NOTES:

1. ASSEMBLED LENGTH TOLERANCE: $\pm 2\%$ OF LENGTH
2. CONNECTOR MATERIALS:
 HOUSING: HIGH TEMP THERMOPLASTIC, BLACK, UL94-V0
 CONTACT: COPPER ALLOY
 RETENTION BAR: HIGH TEMP THERMOPLASTIC, BLACK, UL94-V0
 PLASTIC WOVEN BRAID: PET
 TAPE: TBD
 LABEL: TBD
3. CONTACT PLATING:
 SEPARABLE INTERFACE:
 PERFORMANCE-BASED PLATING, QUALIFIED TO MEET THE
 REQUIREMENTS OF FCI PRODUCT SPECIFICATION GS-12-1096
 INCLUDING TELCORDIA GR-1217-CORE (NOVEMBER 1995)
 CENTRAL OFFICE TEST SEQUENCE
4. LABEL DETAILS:
 MANUFACTURE CODE OR NAME
 FCI PART NUMBER - REVISION
 DATA CODE (YYYY/MM/DD FORMAT) - SERIAL #
 COUNTRY OF ORIGIN

 FONT SHALL BE CLEARLY VISIBLE AND BLACK IN COLOR
5. CABLE PACKAGING PER FCI GLOBAL STANDARD: GS-14-1272
6. PACKAGING MEETS GS-14-920 LEAD FREE LABELING SPECIFICATION
7. LEAD FREE PRODUCTS MEET EUROPEAN UNION DIRECTIVES AND
 OTHER COUNTRY REGULATIONS AS DESCRIBED IN GS-47-0004
8. REFERENCE APPLICATION SPEC: GS-20-0412
9. ALL CABLE ASSEMBLIES SHALL BE TESTED 100% FOR CONTINUITY
 AS DEFINED IN WIRING LIST

10. UNLESS OTHERWISE SPECIFIED ALL CABLE ASSEMBLIES SHALL BE
 100% HI-POT TESTED BY APPLYING 300V DC FOR MINIMUM OF 10ms,
 UNLESS ACTIVE COMPONENTS ARE USED IN THE ASSEMBLY
11. A " \triangle " SYMBOL WILL BE NEXT TO ANY DIMENSION, VIEW, OR NOTE
 WHICH HAS BEEN MODIFIED WITH THE CURRENT DRAWING REVISION.
 THE CURRENT REVISION WILL BE SHOWN IN THE SYMBOL
12. MATING BOARD CONNECTOR P/N: 10121056-12JLF
13. UNLESS OTHERWISE SPECIFIED,
 KEY/KEY BUSHING IS NOT INCLUDED
14. CONNECTOR ASSEMBLIES SHOWN ARE FOR REFERENCE ONLY AND
 MAY NOT SHOW ALL PART DETAIL. REFERENCE CONNECTOR
 ASSEMBLY DRAWINGS FOR COMPLETE DETAILS
15. FINISHED ASSEMBLY SHALL BE IN A SUITABLY SIZED
 POLY BAG OR EQUIVALENT
16. WIRING LIST IS SHOWN FOR COLUMNS 1 AND 2.
 ALL OTHER COLUMNS FOLLOW THE SAME PATTERN AS
 SHOWN IN THE IMLA WIRING LIST
17. APPLICABLE PANEL MOUNTING BRACKET PART NUMBERS:
 SINGLE PORT: 10127037-101
 DUAL PORT: 10127037-102
 FOUR PORT: 10127037-104
18. PINS FOR LOW-SPEED CIRCUITS
 L1-L8 ARE NOT TERMINATED

spec ref -		dr	J. WINEY	2014-10-02	projection	mm	size	A3	scale	1:2
tolerance std	TOLERANCES UNLESS OTHERWISE SPECIFIED	eng	K. WEBER	2014-10-02			ecn no		rel level In Work	
ASME Y14.5		chr	K. WEBER	2014-10-02						
-		appr					product family -			
surface <input checked="" type="checkbox"/>		linear	0.X	±	title EXAMAX 10, 4X8-2.0mm PITCH PASSIVE LATCH BACK PLANE CABLE ASSY		dwg no 10129954		rev 2	
		0.XX	±							
		0.XXX	±							
	angular	0°	±°	www.fci.com	cat. no.	-	Product - Customer Drw		sheet 6 of 6	