

REVISIONS			
REV	DESCRIPTION, ECN, EAR NO.	DATE	APP'D
A	PROPOSAL PER EAR# RJ19114	SEP18/19	L.CHAN

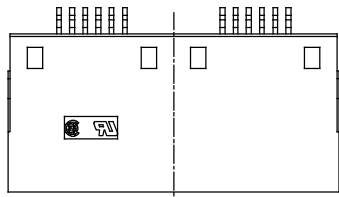

TOP VIEW

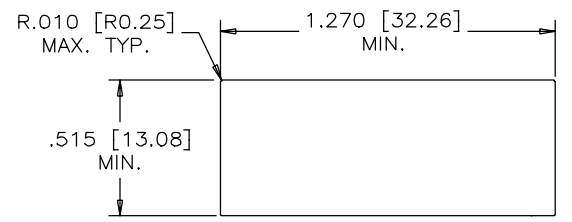

RECOMMENDED PANEL CUTOUT

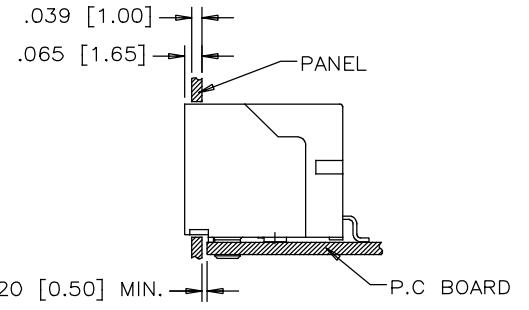

RECOMMENDED PANEL CUTOUT

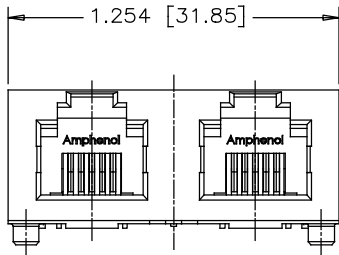

FRONT VIEW

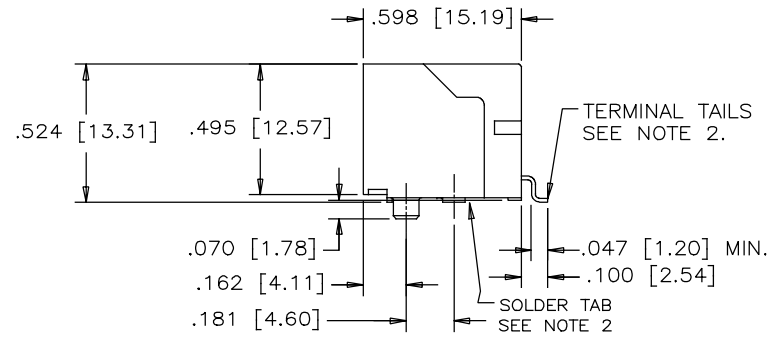

SIDE VIEW

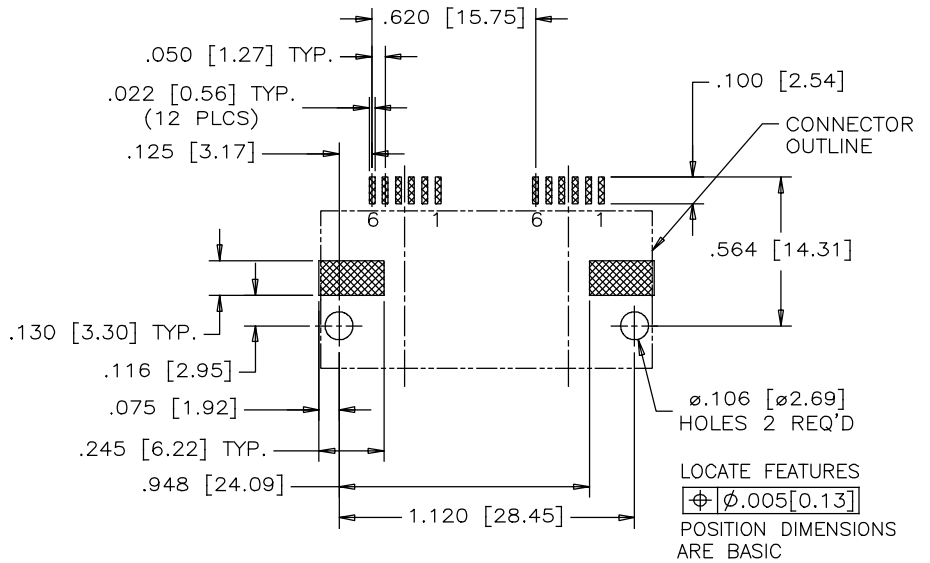

RECOMMENDED P.C.B. LAYOUT  
(COMPONENT SIDE OF BOARD)  
TOLERANCE: ±0.05 [.002]

NOTES:

1. MATERIAL:

- HOUSING: HIGH TEMPERATURE THERMOPLASTIC  
FLAMMABILITY RATING UL 94V-0  
COLOR:BLACK
- CONTACTS: PHOSPHOR BRONZE  
PLATING: 20 μ" [0.508 MICRONS]  
MIN. GOLD ON MATING SURFACES.  
50 μ" [1.27 MICRONS]  
MIN. NICKEL UNDERPLATE  
100 μ" [2.54 MICRONS]  
MIN. MATTE TIN OR GOLD FLASH  
ON CONTACT TAILS.
- SOLDER TAB: COPPER ALLOY WITH TIN FINISHED.

2. COPLANARITY SPECIFICATION:

WITH THE MODULAR JACK SITTING ON A LEVEL SURFACE, THE MAXIMUM GAP BETWEEN THE LEVEL SURFACE AND ALL TERMINAL TAILS AND BOTH FITTING NAILS IS .004 [0.10].

AMPHENOL PART NUMBER: RJSSE-7060-02T



UNLESS SPECIFIED OTHERWISE	DRAWN RONNIE.C	SEP18/19	Amphenol Canada Corp. Commercial Products
PRIMARY UNITS INCHES	CHECKED KELVIN.T	SEP18/19	
SECONDARY MILLIMETERS	M.E. APP'D		2 PORTS SURFACE MOUNT JACK, UNSHIELDED, WITH HOLD DOWN BRACKET, 6 POSITION, 6 CONTACTS, T&R PACKAGING, -RoHS COMPLIANT
REFERENCE IN PARENTHESES	Q.A. APP'D		
GENERAL TOLERANCES	DWG APP'D		DWG NO. P-RJSSE-7060-02T
1 DECIMAL PLACE	ENG. REL NO. EAR# RJ19114		
2 DECIMAL PLACES	REF.		REV A
3 DECIMAL PLACES ±.015			
ANGULAR DEGREES ±1.5°	THIRD ANGLE PROJECTION	DO NOT SCALE DRAWING	CODE ID NO. 03554   DWG SIZE X   SCALE 1:1   SHEET 1 OF 2

REVISIONS			
REV	DESCRIPTION, ECN, EAR NO.	DATE	APP'D
A	PROPOSAL PER EAR# RJ19114	SEP18/19	L.CHAN

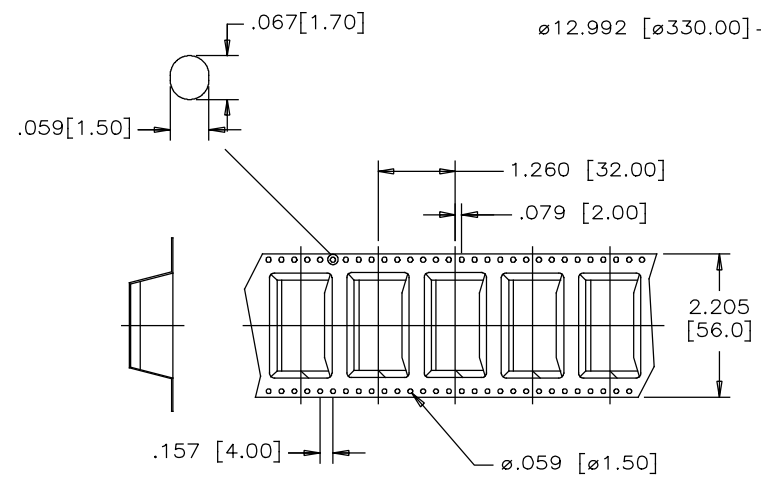
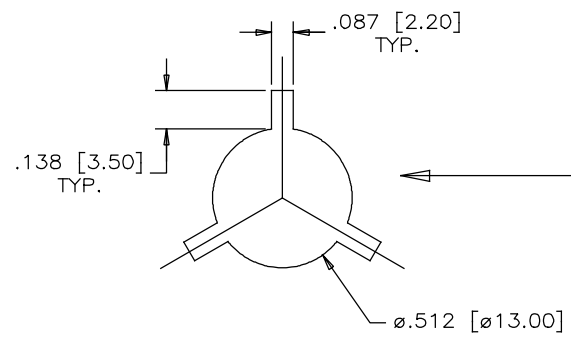
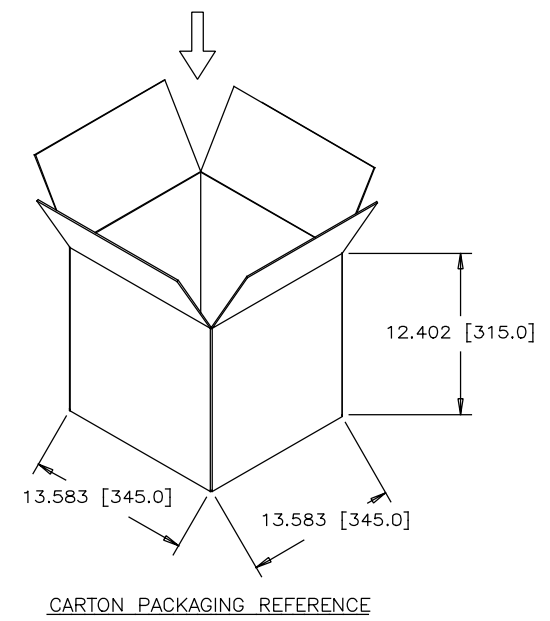
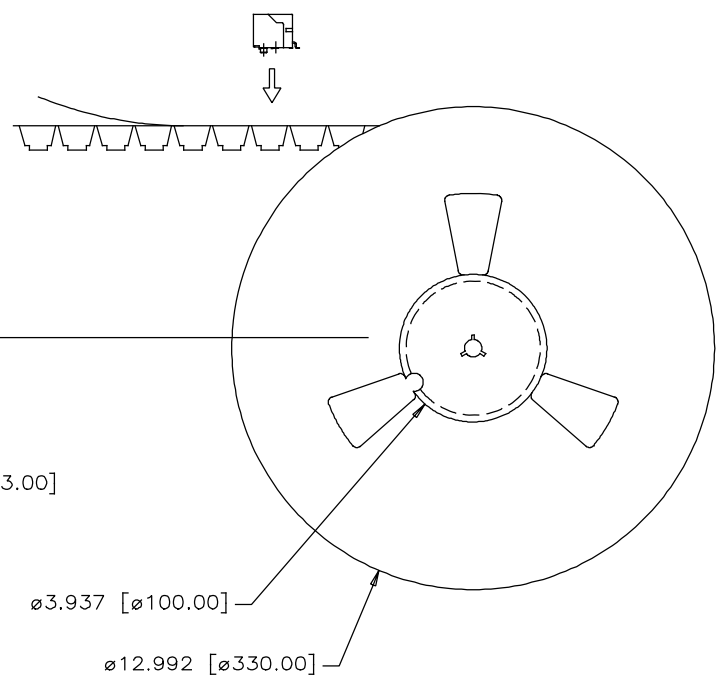
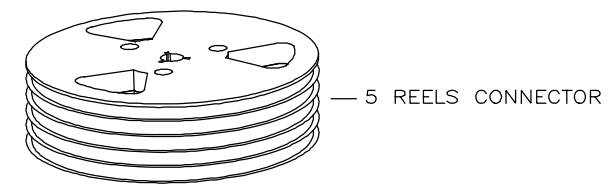
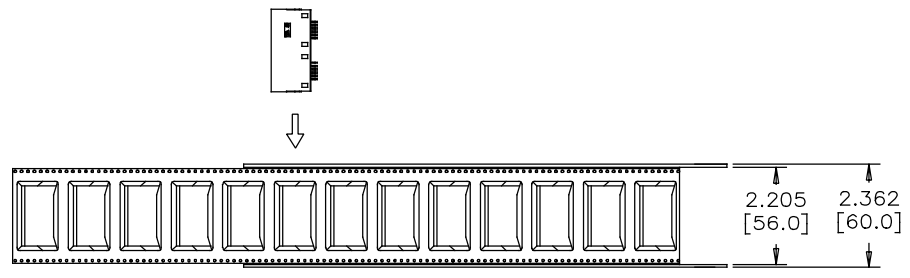

PACKAGING NOTES:

- ONE REEL SHOULD HOLD 100 CONNECTORS.
- A FULLY LOADED CARTON SHOULD CONTAIN 5 REELS (500 PCS) OF CONNECTOR.

THIS DOCUMENT CONTAINS PROPRIETARY INFORMATION AND SUCH INFORMATION MAY NOT BE DISCLOSED TO OTHERS FOR ANY PURPOSE OR USED FOR MANUFACTURING PURPOSES WITHOUT WRITTEN PERMISSION FROM AMPHENOL CANADA CORP.

UNLESS SPECIFIED OTHERWISE	DRAWN RONNIE.C	SEP18/19	Amphenol Canada Corp. Commercial Products
PRIMARY UNITS INCHES	CHECKED KELVIN.T	SEP18/19	
SECONDARY MILLIMETERS	M.E. APP'D		2 PORTS SURFACE MOUNT JACK, UNSHIELDED, WITH HOLD DOWN BRACKET, 6 POSITION, 6 CONTACTS, T&R PACKAGING, -RoHS COMPLIANT
REFERENCE IN PARENTHESES	Q.A. APP'D		
GENERAL TOLERANCES	DWG APP'D		DWG NO. P-RJSSE-7060-02T
1 DECIMAL PLACE	ENG. REL NO. EAR# RJ19114		
2 DECIMAL PLACES	REF.		REV A
3 DECIMAL PLACES ±.015	THIRD ANGLE PROJECTION	DO NOT SCALE DRAWING	
ANGULAR DEGREES ±1.5°			CODE ID NO. 03554   DWG SIZE X   SCALE N/A   SHEET 2 OF 2